

# 15" Cutout and Torque Limits

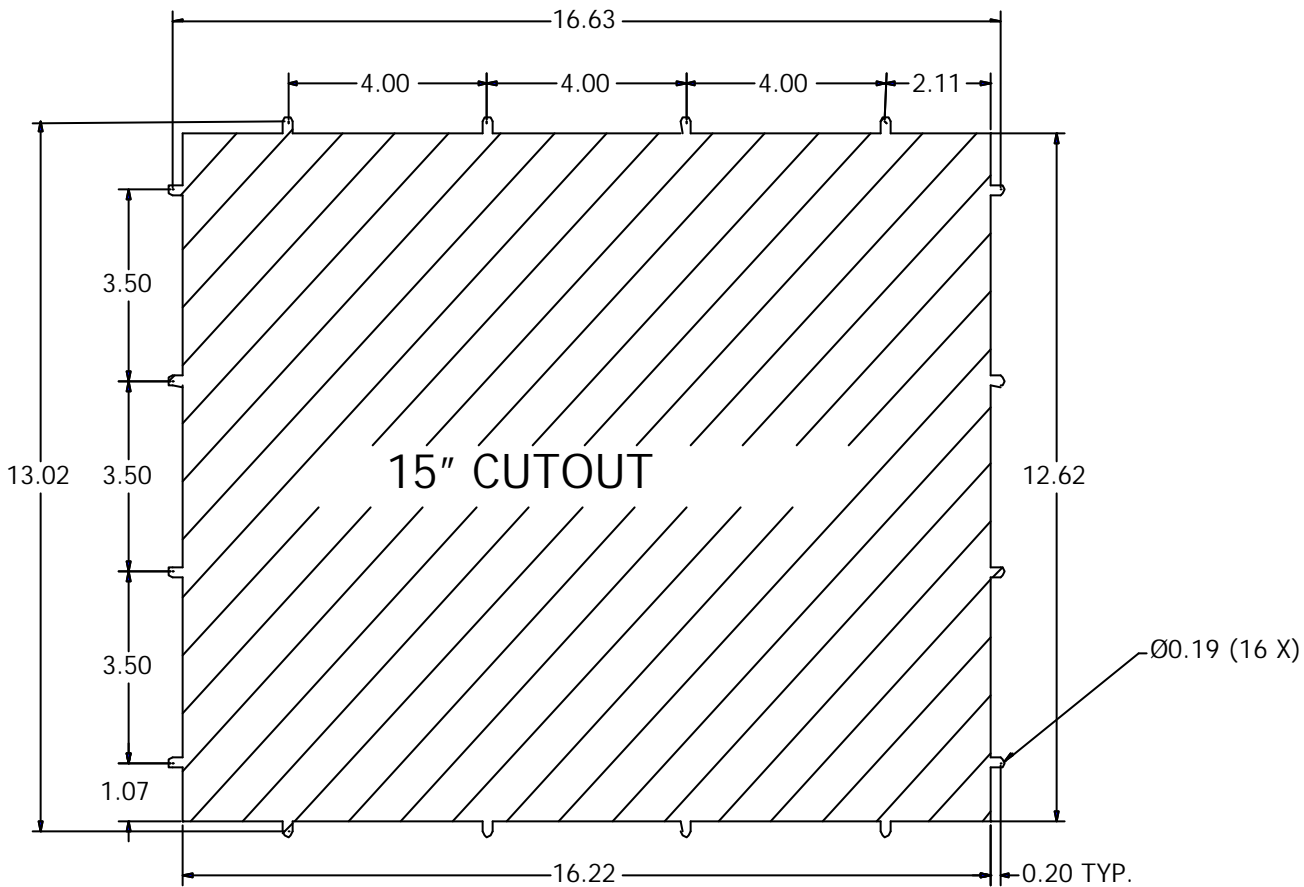

## Torque Limits for Steel Studs

**CAUTION:** Care should be exercised when tightening the nuts. The fasteners must be tightened to obtain a proper seal. Do not over tighten the nuts. Doing so will strip the steel studs. The following torque limits should not be exceeded:

**14 FOOT-POUNDS FOR #8-32 NUTS**

Figure 2-1: 15" Cutout and Torque Limits